

Maintenance Instructions

100, 600, 500 Series Valve



Packing Rebuild Kit Components:

Belleville Springs (X2)	Packing Pusher	Upper Packing	Lower Packing	Packing Support	Lubricant (MCD-111 & MCG-130)

Disassembly

1. Remove the handle by loosening the set screw using a 3/32" Allen wrench.

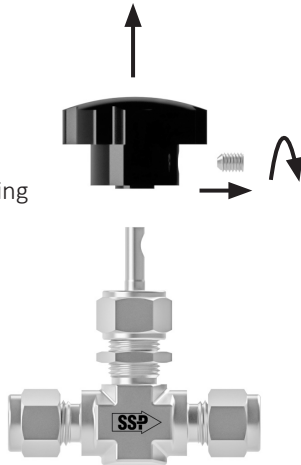

2. Use a wrench to remove the packing nut.

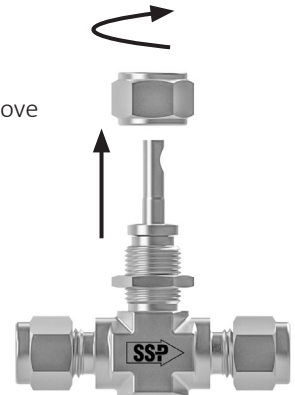

3. Slide the Belleville spring washers up over the stem.

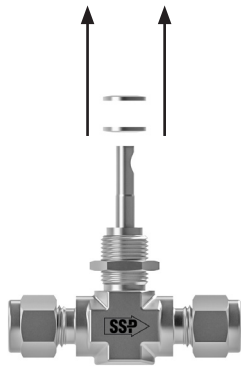

4. Turn the stem counter clockwise to remove the stem and packing from the body.

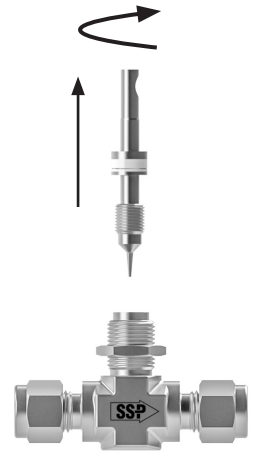

5. The packing consists of the packing pusher, upper packing, lower packing, and packing support. Slide each component up and over the stem.

Discard old packing components and remove new packing kit components from packaging.



Reassembly

6. Apply MCG-111 lube over the entire upper and lower packing parts. Replace the new packing components in the correct order: Packing support, lower packing, upper packing, packing pusher.

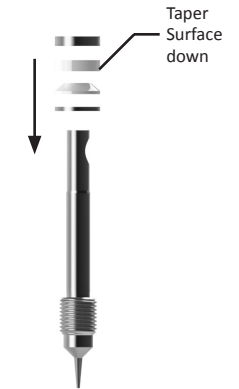

7. Apply MCG-130 lube to the threads on the stem. Turn the stem clockwise into the body so that the packing completely fits the packing cavity in the body.

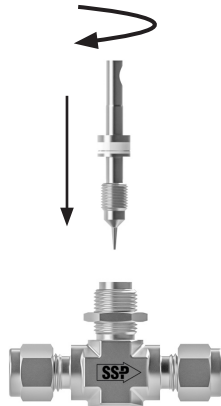

8. Replace the Belleville springs by sliding them over the top of the stem. The bottom spring should have the concave side facing up. The top spring should have the concave side facing down.

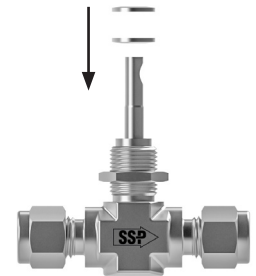

9. Apply MCG-130 lube to the threads on the packing nut. Reassemble the packing nut over the stem by using a torque wrench to thread the nut onto the body. See torque chart.

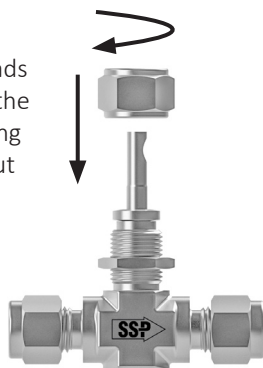

10. Place the handle over the stem and align the set screw hold with the drill point on the stem. Turn the set screw with a 3/32" Allen wrench until "snug" to secure the handle to the stem.

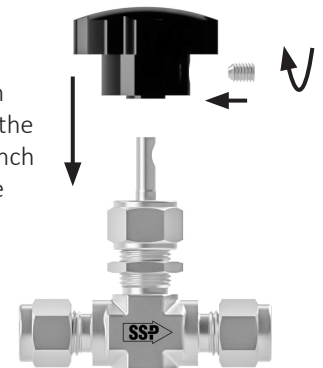

Packing Nut	316SS		Brass	
	Min	Max	Min	Max
5/8" Hex	2.5 ft-lb	4 ft-lb	2.5 ft-lb	4 ft-lb
7/8 Hex	7 ft-lb	8 ft-lb	2.5 ft-lb	4 ft-lb