



Ball Valve Mounting Bracket Kit Installation Instructions

This document shows how to install an ISO 5211 dimensionally compliant mounting bracket and coupling to the following FloLok ball valves:

- EB series (all)
- FB valves (all)
- TB series (all)



WARNING

Before removing any installed valve you must:

- depressurize the system
- Cycle the valve
- Purge the valve



CAUTION

You must verify the desired flow patterns after these assembly steps are completed.



CAUTION

Actuated assemblies must be properly aligned and supported. Improper alignment or inadequate support of the actuated assembly may result in leakage or premature valve failure.



The valve shown is a EB series ball valve

Bracket Kit Contents

Mounting Bracket	Coupling	Coupling Set Screw	Lock Washers	Hex Head Cap Screw
				

Tool Requirements

Open-End Extension	
Hex Bit or Wrench	
Torque Wrench	<p>capable of applying up to 400 in.·lb (45.2 N·m, 46 cm·kg)</p>

Actuator Preparation

1. Insert the **Coupling** into the **actuator drive socket**

EB Series FB Series	Align the coupling flats to match valve stem flats so the coupling set screw will contact the larger stem flat. (See Valve Preparation.)
TB Series	Align the coupling set screw with the valve stem hole. (See valve preparation)

Note: Coupling orientation shown is an example. The valve flow pattern will determine actual coupling orientation.

Valve Series/Size	Panel Nut	Coupling Set Screw	Handle Set Screw
	Open-End Extension	Hex Bit	Hex Wrench
EB41G, EB42G	3/4 in.	5/64 in.	5/64 in.
EB43G	1 in.	3/32 in.	3/32 in.
EB44G	1 1/4 in.	1/8 in.	1/8 in.
EB45G	1 5/8 in.	5/32 in.	5/32 in.
FB36	1 in.	3/32 in.	3/32 in.
FB38	1 5/8 in.	5/32 in.	5/32 in.
TB83	1 1/8 in.	3/32 in.	3/32 in.

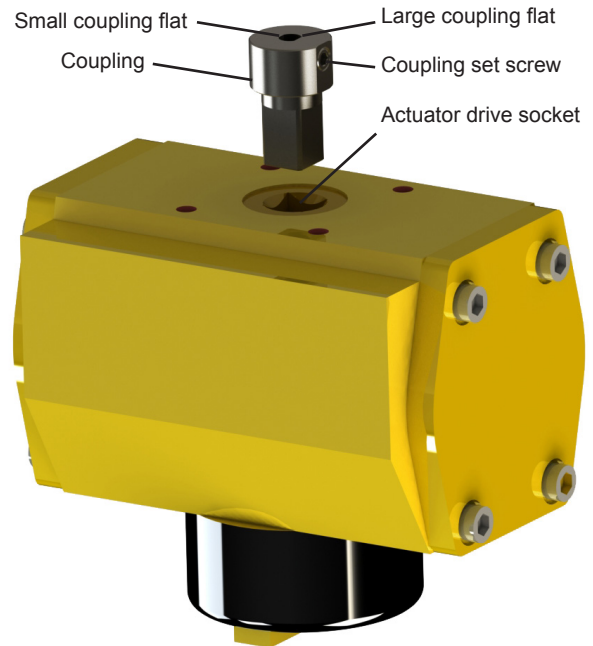

2. Place the **mounting bracket** on the **actuator** and orient in the desired position. Verify the **coupling** is in the proper position to maintain desired flow pattern.

ISO 5211 Flange Size	Hex Head Cap Screw Size	
	Metric	Fractional
F03, F04	8 mm	5/16 in.
F05	10 mm	7/16 in.
F07	13 mm	1/2 in.

3. Attach the **mounting bracket** to the actuator with (4) **Lock washers** and (4) **Hex head cap screws** and tighten to the torque shown below.

ISO 5211 Flange Size	Torque Required		
	in.·lb	N·m	cm·kg
F03, F04	40	4.5	46
F05	75	8.5	86
F07	125	14.1	144

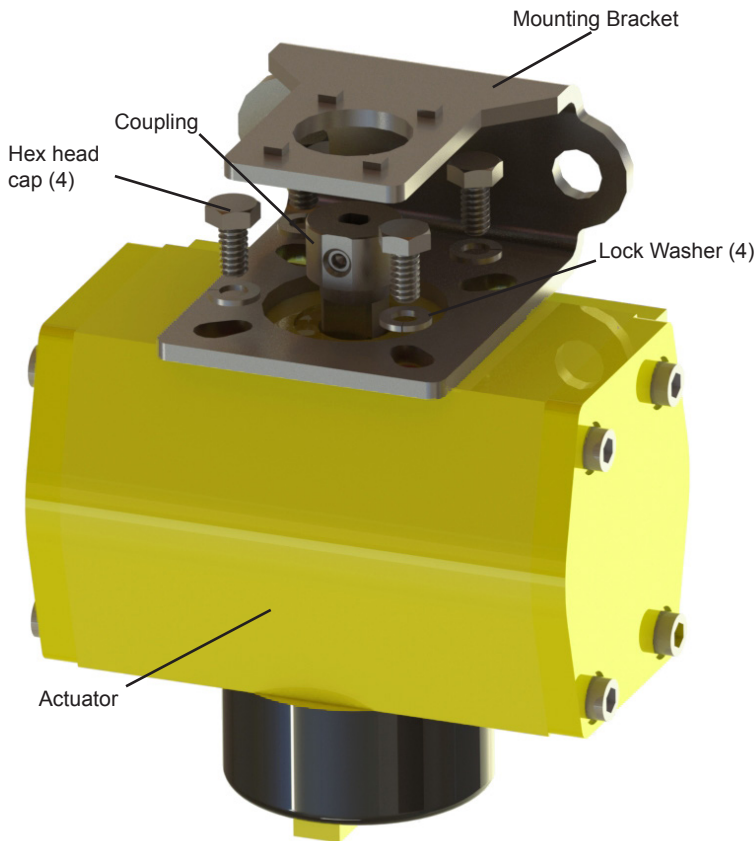

Valve Preparation

1. Put valve in the desired position. Loosen set screw and remove handle from valve.
2. Verify the orientation of the stem flats / hole for insertion into coupling. Visually check valve port(s).

2-way valves in open position

- EB series
- FB series

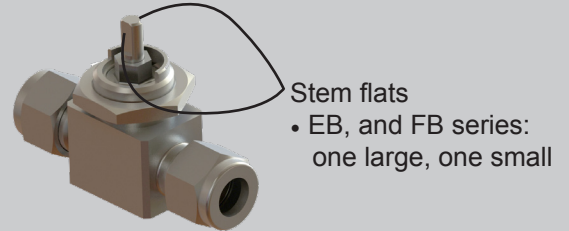

2-way valves in closed position

- EB series
- FB series

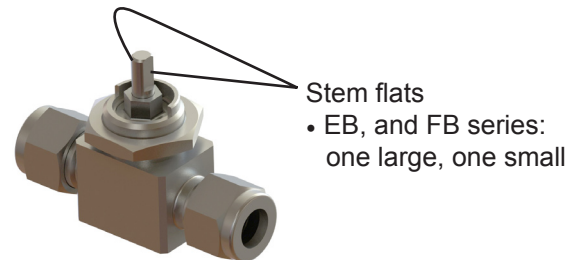

2-way valves in open position

- TB series

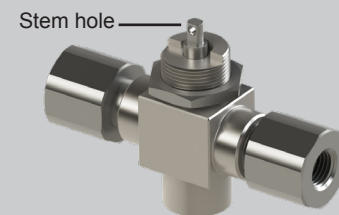

2-way valves in closed position

- TB series

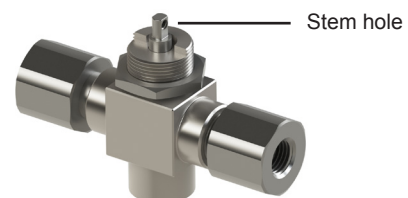

Mounting Instructions

1. Unthread the **panel nut** from the **valve**.
2. Place **panel nut** on the **coupling**.
3. Insert the **valve** through the **mounting bracket**, **panel nut**, and **coupling**. Loosen **coupling set screw** if necessary.
4. Verify desired flow pattern.
5. Thread the **panel nut** onto the **valve** and tighten to the torque shown below.

6. EB series and FB series: Slide coupling down to fully engage stem flats. No flat should be visible when fully engaged.

TB series: Slide the coupling down to engage the stem flats. Align set screw with set screw recess.

7. Tighten the coupling set screw to the torque shown below.
8. Test for proper valve operation by applying air pressure as specified by the actuator manufacturer.

Valve Series/Size	Torque Required		
	in. · lb	N · m	cm · kg
EB41G, EB42G	50	5.7	58
EB43G	150	17	173
EB44G	250	28.3	288
EB45G	400	45.2	461
FB36	150	17	173
FB38	400	45.2	461
TB83	100	11.3	115

Valve Series/Size	Torque Required		
	in. · lb	N · m	cm · kg
EB41G, EB42G	40	4.5	46
EB43G	100	11.3	115
EB44G	100	11.3	115
EB45G	200	22.6	230
FB36	100	11.3	115
FB38	200	22.6	230
TB83	15	1.7	17

